



# Submittal Form: 4-way Mixing Valve Board

Infloor's 4-way Mixing Valve Board is a secondary loop system designed for use in conjunction with a primary loop. It includes all of the mechanical needs for most secondary systems and can be utilized for systems with 1-7 zones. For larger systems, multiple boards can be used.

4-way Mixing Valve Board			
Part #	# Zones	Pipe Size	Pump
32214	1	3/4"	UP 15-58
32215	2	3/4"	UP 15-58
32216	3	1"	UP 15-58
32217	4	1"	UP 15-58
32218	5	1-1/4"	UP 26-99
32219	6	1-1/4"	UP 26-99
32220	7	1-1/4"	UP 26-99

Board Size: 32" x 36"

**Included:**

- Secondary Pump
- Pressure Differential Bypass Valve
- Zone Control Valves
- 4-way Mixing Valve
- Zone Controller  
(two included for 6-7 zone boards)
- 24VAC Transformer

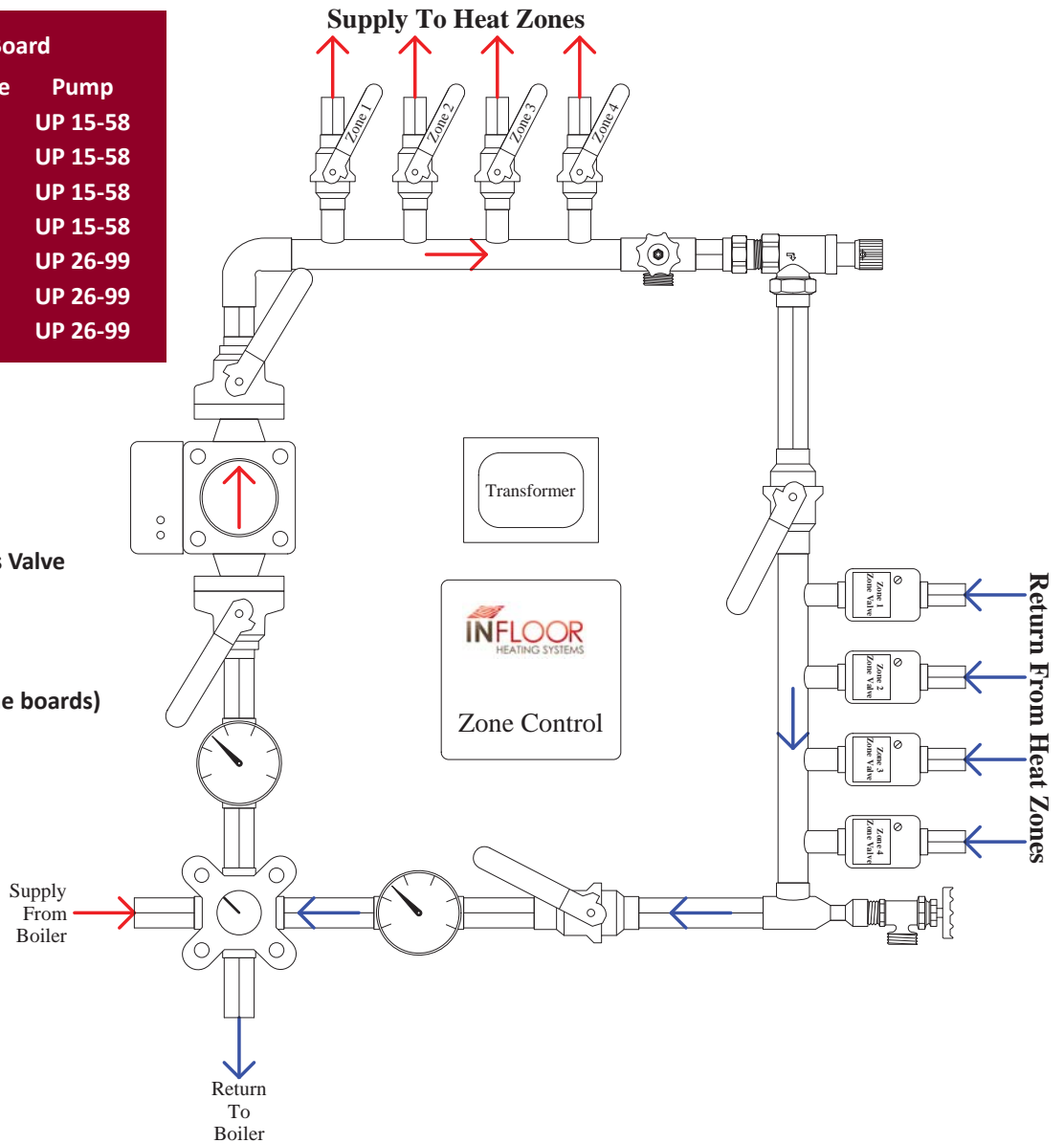

Infloor Inc.  
PO Box 5283  
Buena Vista, CO 81211  
800-608-0562  
719-395-3555-fax

Date: \_\_\_\_\_

Project Name: \_\_\_\_\_

Engineer: \_\_\_\_\_

Submitted By: \_\_\_\_\_