

i-Link 30061-30062

MULTI-ZONE ZONE VALVE CONTROL

INSTALLATION AND OPERATING INSTRUCTIONS

APPLICATION

The **i-Link** series multi-zone zone valve controller is operated by low voltage thermostats or any other low voltage controllers having an SPST switching action. The **i-Link** controller provides intermediate switching to permit up to six zone valves and a boiler operating control in a multi-zone hydronic heating system.

Intelligent Linking System (*i-Link*) allows unlimited zone expansion with additional *i-Link* controllers. Field selectable priority with protection timer prevents freeze-ups in the event of a priority zone failure. The three-minute delay timer let the two wire type zone valve fully open before turning on the circulator.

The panel provides EZ screwless terminal blocks for connections to the thermostats. LED indicators on the front panel provides functional status and easy troubleshooting.

FEATURES

- Front panel indicator lights
- Field selectable Priority
- Priority timer for protection of a priority zone malfunction and prevention of freeze-ups in the heating zones
- Unlimited zone expansion
- Dual Isolated End Switches
- Three-minute End Switch delay timer for two wire type zone valve applications. Circulator will start only after the zone valve is fully opened.
- DIP switch for easy setup of two wire type zone valve applications. No need to hook up wire jumper on the third and fourth terminals on each zone
- Works with two, three or four wire type zone valves and thermostats
- Compact and modern design
- Safety design with all electronic components hiding behind the enclosure
- Fuse protection
- Simplified wiring
- Contractor friendly PCB layout
- Easy-Connect Screwless Terminals
- 24VAC transformer output with common terminal provides compatibility with electronic thermostats
- Universal thermostat compatibility
- 100% Factory Tested
- Extended three year warranty

SPECIFICATIONS

Model:	30061 4 Zone Valve Control 30062 6 Zone Valve Control
Power Supply:	24 VAC, 50/60Hz
Dimensions:	6 3/8"(W) x 6 5/8"(H) x 2 3/4"(D)
Electrical Switch Rating:	10 A 1/3 HP @ 120VAC
Thermostat Anticipator Setting:	0.18 A
Enclosure:	Flame Retardant Plastic 94V0
Shipping Weight:	3 lbs.

CAUTION!

1. To prevent electrical shock hazard, disconnect power supply before installing.
2. All wiring must comply with national and local electrical codes, ordinances, and regulations.
Never connect the load terminals to a load that takes more current than the amount listed for the relay in the electrical ratings.
3. Azel Technologies is not responsible for damages resulting from misuse of its products.
4. 12-22 gauge wire is recommended for thermostat connections.
5. This literature is provided for informational purposes only.

MOUNTING

Mount the **i-Link** controller to a suitable surface. Slotted keyholes and standard holes are provided for mounting purposes.

ROUGH-IN WIRING

Loosen the screws on the top and bottom of the enclosure and remove the wiring covers by swinging them away from the base (grey color) with the edges of the covers as pivot (see Figure 1).

The base has standard 7/8" (22mm) knockouts which accept common wiring hardware and conduit fittings. Before removing the knockouts, check the wiring diagrams and use the chamber with common voltages.

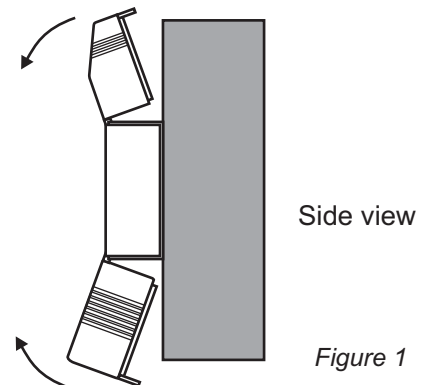

OPERATION

When any zone (thermostat) calls for heat, the corresponding green light turns on and zone valve is energized. When zone valve is fully opened, green light turns into orange light and End Switches (X1-X1 and X2-X2) are closed (to start boiler and circulator control).

DOMESTIC HOT WATER PRIORITY OPERATION

When zone 1 priority switch is set to **ON**, zone 1(domestic hot water zone) has priority control over zone 2 to 6(heating zones). If zone 1 is calling for heat, zone valves 2 to 6 are disabled until zone 1 domestic hot water demand is satisfied.

When zone 1 priority switch is set to **OFF**(factory setting), all zones operate independently of each other.

When zone 1 priority switch is set to **TIMER**(Priority Protection Timer mode), if the priority zone calls for domestic hot water for more than one hour(eg. In case of a priority zone failure such as a faulty indirect water heater controller keeps calling for heat or leaking situation), all the heating zones (2 to 6) are released from locking out and they are returned to normal operation. This feature helps prevent freeze-ups in the event of zone 1 failure. Once the priority zone 1 is satisfied, the priority timer is reset to allow priority for another one hour.

i-Link Zone Expansion

i-Link zone valve controller can be expanded to unlimited number of zones with additional **i-Link** zone valve controllers. Simply connect terminals "1 2 3" of the "Master" unit to terminals "1 2 3" of the "Slave" unit with 18AWG wires. More units can be connected in the similar manner. Use the Master/Slave Switch to define the unit as "Master" or "Slave". The priority zone of the "Master" unit (if zone 1 priority switch is set to **ON or Timer**) will turn off all other zones of the "Slave" units. After expansion, all the units will act as a single unit. This means only one set of X-X(End Switch) terminal is needed to connect to the "TT" on the boiler control. Factory default setting is "Master".

L.E.D. SYSTEM STATUS INDICATION LIGHTS

Green zone light (1-6) indicates that the thermostat is calling for heat and the corresponding zone valve is energized. Note: This zone light is multicolour which can be changed to orange colour.

Orange zone light (1-6) indicates End Switches (X1-X1 & X2-X2) are closed and the zone valve (four wire type with an End Switch) is fully open. In case of two wire type zone valve, the zone valve is energized. If the 3-minute ES delay timer is set to OFF, End Switches are closed. If the ES(End Switch) delay timer is set to ON, End Switches are closed three minutes after thermostat calls for heat.

GREEN Power light indicates presence of power supply.

GREEN solid Priority Timer light indicates that the one-hour timer is started. GREEN flashing light indicates one hour priority timer is expired and all heating zones are released from locking out. All

TWO WIRE TYPE ZONE VALVE

When two wire type zone valve is used, JUMPER 3&4 DIP switch can be set to ON for each corresponding zone so that there is no need to put a wire jumper across terminal R-R. Also, ES (End Switch) Delay Timer can be set to ON. This allows a delay of three minutes on closing the X1-X1 and X2-X2 End Switches after thermostat calls for heat which gives sufficient time for zone valve to fully open.

ELECTRONIC THERMOSTATS

ALL **i-Link** controls are compatible with 2, 3 or 4 wire type thermostats. 24VAC Out can be used to supply power to the thermostat. For thermostats requiring the 24VAC Common, simply connect C terminal from the thermostat to COM terminal on the 24VAC output.

Infloor 29019 thermostat is recommended for use with **Link i-Controls**.

NOTE ON WIRING INSTRUCTIONS

30062 units are used as examples on the wiring diagrams. 30061 units can be wired in the same manner.

If 29019 digital thermostat is used, it can be powered by connecting terminal 4 & 5 of 29019 to 24VAC Out (R & C) of i-Link controls. For simplicity, this connection is not shown in all example.

TERMINAL DESCRIPTION

Dry Contact Terminals

X1	X1	Dry Contact End Switch
X2	X2	Dry Contact End Switch

Low Voltage Terminals

24VAC IN/R	24 VAC transformer hot input
24VAC IN/C	24 VAC transformer common input
24VAC OUT/R	24 VAC transformer hot output
24VAC OUT/C	24 VAC transformer common output
ZONE EXPANSION/1 2 3 4	ZONE expansion to additional i-Link zone valve controls

THERMOSTATS

R/T1	Zone 1 24VAC Thermostat Hot Terminal
W/T1	Zone 1 Thermostat Switching Terminal
R/T2	Zone 2 24VAC Thermostat Hot Terminal
W/T2	Zone 2 Thermostat Switching Terminal
R/T3	Zone 3 24VAC Thermostat Hot Terminal
W/T3	Zone 3 Thermostat Switching Terminal
R/T4	Zone 4 24VAC Thermostat Hot Terminal
W/T4	Zone 4 Thermostat Switching Terminal
R/T5	Zone 5 24VAC Thermostat Hot Terminal
W/T5	Zone 5 Thermostat Switching Terminal
R/T6	Zone 6 24VAC Thermostat Hot Terminal
W/T6	Zone 6 Thermostat Switching Terminal

Zone 1/Y Y	Zone 1 terminals for zone valve motor connections
Zone 1/R R	Zone 1 terminals for zone valve end switch connections
Zone 2/Y Y	Zone 2 terminals for zone valve motor connections
Zone 2/R R	Zone 2 terminals for zone valve end switch connections
Zone 3/Y Y	Zone 3 terminals for zone valve motor connections
Zone 3/R R	Zone 3 terminals for zone valve end switch connections
Zone 4/Y Y	Zone 4 terminals for zone valve motor connections
Zone 4/R R	Zone 4 terminals for zone valve end switch connections
Zone 5/Y Y	Zone 5 terminals for zone valve motor connections
Zone 5/R R	Zone 5 terminals for zone valve end switch connections
Zone 6/Y Y	Zone 6 terminals for zone valve motor connections
Zone 6/R R	Zone 6 terminals for zone valve end switch connections

TYPICAL WIRING DIAGRAMS

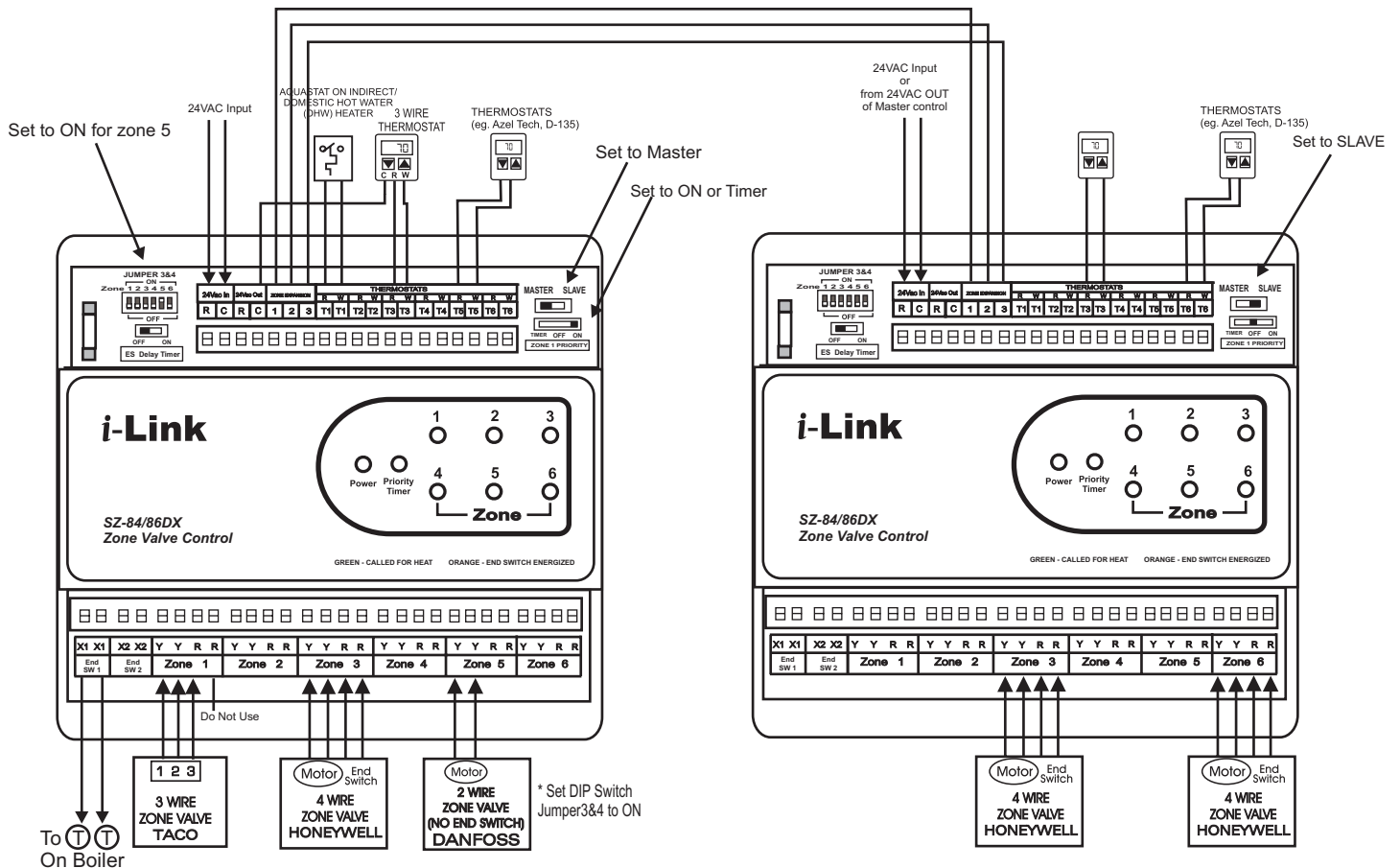
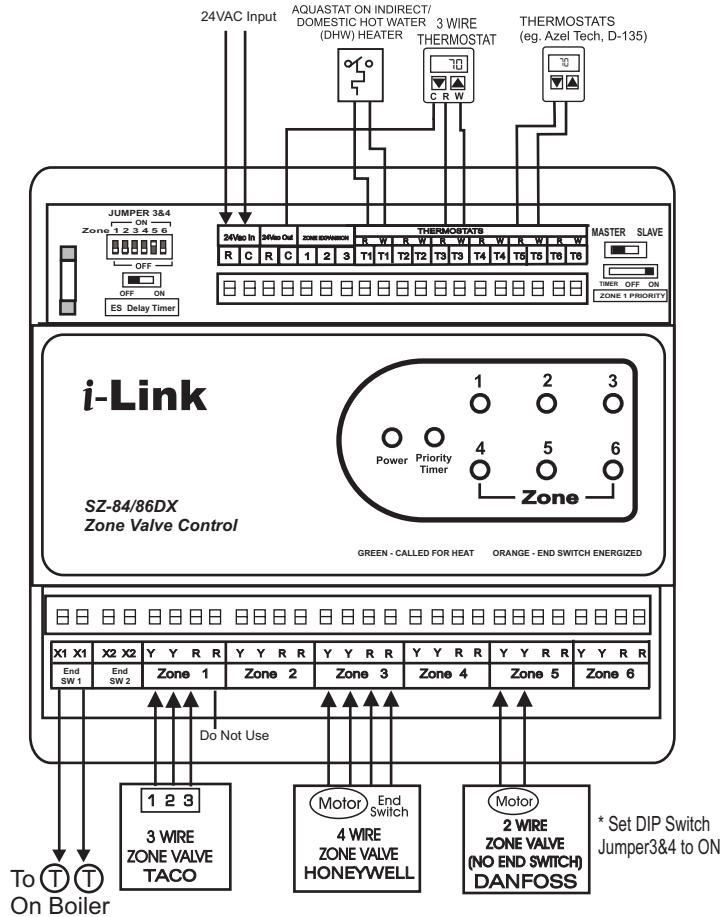

Domestic Hot Water Priority with zone expansion by adding 30061

TROUBLE SHOOTING

When 24VAC is supplied to **i-Link** controllers, the green power light should be on.

- If the thermostat is closed and green zone light is on, the power should be supplied to the zone valve. If the zone valve is not actuated or if the zone valve end switch is not closed (light is not turning orange color), check the zone valve for functionality.
- ***If green zone (1-6) light is on all the time***, check the thermostat for functionality. Remove the thermostat from the **i-Link** controller and put a piece of wire across R/T and W/T terminal to simulate the thermostat calling for heat. If everything works properly, then the thermostat is faulty.
- ***If the green power light is off***, check the fuse and the presence of 24VAC power supply.

Infloor Sales & Service

www.infloor.com

Please visit our website for other products

P.O. Box 4945
503 Gregg Drive.
Buena Vista, CO, 81211
Ph: 800-608-0562 Fax: 719-395-3555
Email: info@infloor.com